

# Marque

SPORTS CAR REGISTER NORTH QUEENSLAND Inc.

Newsletter

*A Club for All Enthusiasts*

Volume 1, Issue 1      January 2011

## A WORD FROM THE EDITOR - PAUL GILBERT



I have taken on the dubious honour/role of putting together your Newsletter. Wilf is a big act to follow. So as I said this is your newsletter, and you can make it what you want. Please send jokes, news items and your personal take on things for submission. Published items are at the discretion of the editor.

I chose this photo of a sand car for the only reason that I used to build sandcastle cars during my childhood annual holidays in England at a little place called Point Clear, opposite Brightlingsea on Brightlingsea Creek in



NOTE: photos should not be larger than 100kb and must be a jpg, gif, or png file extension. If you are not sure how to do this give me a call on 0421 112 161

Northeast Essex.

Cars were always high on my interest list in the late fifties and sixties, until I was able to buy my first road going car a Ford Anglia 1949 Tourer A494A and learnt quickly that they require maintenance.

I didn't realize till now that my first registered car is the same age as me.

## In This Issue

PRESIDENTS BLOG	2
MEMBER PROFILE - WARREN SKIMMINGS	3
OFFICE BEARERS	4
LOWNDES & WHEEL - VICTORY IN THE AUSTRALIAN SAFARI	5
FOR SALE	6
CALENDAR	7 - 11
MARQUE REGISTER DETAILS	12
DID YOU KNOW	12

New for this year. A **For Sale Section** that will run for 1 issue. If you want it to stay for the next issue send me an email in the last week of the month to extend the ad to the next issue. .

And a **Member Profile** Section. Who is the first volunteer?

## PRESIDENTS BLOG - MICHAEL SEYMOUR

Welcome all to the new year.

I would like to start the year off with a shot at our new editor who requested a 200 word article from me. 200 words. You have got to be kidding. I don't even know 200 (different) words, let alone know how to spell them. Paul must be suffering from some sort of editor's disease to think I can produce a 200 word article.

Ha. It will never happen.

What is ahead for us this year?

Well there are the usual 7 rounds of the Sprint series plus the "Come and Try Day" at the race track. I spoke to Bryce of Zinc 100.7 FM last night and he confirmed that Zinc will be onboard for yet another year, which will help us to continue to grow this great event. He did mention that he would like to do the Zinc staff challenge again this year after the great success of last year. My answer, definitely.

As you will all know by now, we have a "set the calendar" breakfast on Sunday, 30th January at the Harvey's Range Tea House, meeting at the Dalrymple Pub car park around 8.30am. Breakfast is always good up there and the drive is very relaxing, very lit-

tle traffic.

A new event for the year takes place in Ingham on 3rd and 4th of September. The Ingham "Wings and Wheels Airshow". Our club has been asked to put on a display along with many others. It should be great.

Of course we will have our usual displays, the big Camp Quality Weekend, our usual social drives along with our growing in popularity "Pubs Of Townsville" dinners.

And finally for 2011, there is a rumour going around that the club turns 20 this May. I am attempting to find out the validity of this. If true, I will be arranging an event of some

sort to mark this momentous occasion.

So once we have our calendar set, we will be having our new committees meet so that they can start their new role and get 2011 underway.

Finally, welcome back to all members and welcome to our new committee members, for whom the fun is about to start. Bring it on.

By the way, word count tells me that I have managed to write a 409 word article. Who would have thought it. Maybe Paul is not as silly as he looks.

Zeds Rule

Michael

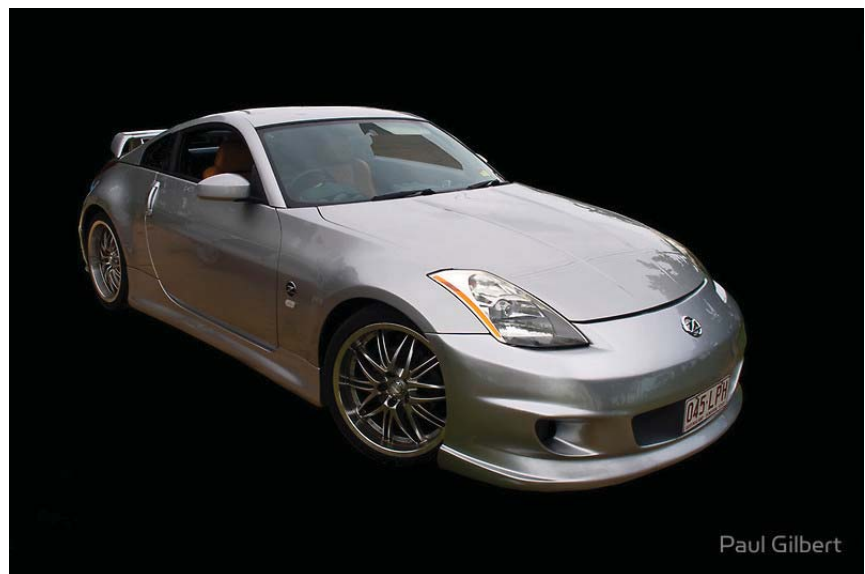

Paul Gilbert

**The editor always gets the final say—Well done with the word count Mike and on time!!**

## MEMBER PROFILE - WARREN SKIMMINGS (SKIMMO)

**Name** - Warren Skimmings (Skimmo)

**How long in Townsville** - I arrived here

in 1966 as 21 year old after hitching hiking up and down the east coast - selected Townsville as the place I wanted to live.

**How long in Marque club** - Foundation

member -[20 years this year]

**Where born** - Sydney but Canberra was where I did most of my schooling and was the place I lived longest before the shift to Townsville

**Cars owned** - In chronological order as far as I can remember [and have probably left some out] -

Austin A30

MGTF

Holden FB customised

Simca Aronde [with Holden six engine]

Mazda 1500

MGA

Falcon XT

Datsun 1600

Holden HZ ute

Mini Cooper S

Holden VS ute

Holden VX ute

Landcruiser 80 series

That does not count the race and rally cars in order

Austin A30 by 3

Mini Cooper S by 3

Datsun 1600 by 2

Datsun 240Z.

Club future - To keep progressing in its various directions but most importantly stay integrated. It is a very interesting club because of its diversity.

### eMail from Skimmo

Wow what a questionnaire - it would read like my life story for a book. I will fill it in with short answers.

I am writing this while parked up living in the Shannon's Super Rig over

looking the Phillip Island race circuit and Bass Strait. In case you

missed the story - I have taken temporary employment driving this rig to

various motoring events while the bloke who normally drives it is recovering from a heart attack. I know this is hard to comprehend living in Townsville but here today it is windy, horizontal drizzle and BLOODY COLD

[weather bureau recons it will get up to 20 today - I don't believe it will get that hot].

Skimmo

**“I'M LIVING IN THE SHANNON'S SUPER RIG OVER LOOKING THE PHILLIP ISLAND RACE CIRCUIT AND BASS STRAIGHT”**



**NOTE: If anyone would like to submit a short piece on themselves as Skimmo has done please send me an email (ed)**

## OFFICE BEARERS

President	Michael Seymour	Ph 0413806567, mikes@wesfil.com.au
Vice President	Warren Skimmings	Ph (h) 47733274, skimmo@ssq.com.au
Secretary	Alan Nelson	Ph (h) 47794521, 0413551454, Alan_nelson@bigpond.com
Treasurer	Denise Skimmings	Ph (h) 47733274, denise@marquenq.com.au
Editor	Paul Gilbert	Ph 0421112161, pmgilbert@netspace.net.au
Publish	Donn Grierson	Ph (w) 47256344, 0417317376, donn.g@mac.com
Social Committee	Rex Goadby	Ph 0402422324, rexgoadby@bigpond.com
Social Secretary	Josianne Chaunut	Ph 0419761972, pip1@beyondnet.net.au
	Graham Williams	Ph (w) 47245255, 0429673078, grahamwilliams@austchems.com.au
Race Committee	Pat Driscoll	Ph 0418778659, patdriscoll@ssq.com.au
	Lindsay Brown	None recorded
	Les Gibney	Ph (h) 47239190. mopar.les@bigpond.com
	Geoff Parnell	Ph (w) 47736663, (h) 47888143, 0412442984
	Jeff Phillips	None recorded
	George Uren	None recorded
Chief Scrutineer	Geoff Parnell	Ph (w) 47736663, (h) 47888143, 0412442984
Life Members	Alan Nelson, Denise Skimmings, Warren Skimmings, Geoff Parnell, Wilf Hardy	

NOTE: Please make sure your details are correct.

### NOTE TO ALL MEMBERS

The Office Bearers above are not the only role that can exist.  
If you have an interest in any of the club activities and have ideas or would like to help.  
Don't hesitate to call the appropriate person above.

**BE ON THE LOOK OUT  
FROM POTENTIAL  
MEMBERS -  
CARRY A MEMBERSHIP  
FORM WITH YOU**

**THIS IS YOUR CLUB**

## LOWNDES & WEEL - VICTORY IN THE AUSTRALIAN SAFARI

This is the LS1 powered Holden Colorado that Craig Lowndes & co driver Kees Weel drove to victory in the Australian Safari in Western Australia last year.



It was on display at Bayswater Radiators over the Christmas break & I'm so glad I got a first hand look at it - very impressive build up.



We all know Lowndesy, but for those of you who don't know Kees, he is the father of Paul Weel and owner of PWR the well known radiator & inter-cooler (among other things) company.



See the address below for the actual website for more information

[http://www.australiansafari.com.au/\\_webapp\\_681108/Craig\\_Lowndes\\_proves\\_himself\\_an\\_offroad\\_champion\\_while\\_Ben\\_Graham\\_makes\\_it\\_a\\_trifecta\\_of\\_Safari\\_first](http://www.australiansafari.com.au/_webapp_681108/Craig_Lowndes_proves_himself_an_offroad_champion_while_Ben_Graham_makes_it_a_trifecta_of_Safari_first)



Thanks to Donn Grierson for this article

## FOR SALE

### MX6 Race Car

\$3,000 neg.

Seam welded body with full roll cage, lightened to 950 kg kerb weight, fresh 2.2 ltr engine with stock turbo, front mount inter-cooler, and 3" ss exhaust. Suffers boost-cut at 3,500 rpm, but still does low 47s on Kart Track. Tony Keys Phone - 0438285878 eMail - rkeys1@bigpond.com



**THESE ADDS ARE AT NO COST TO YOU. THEY WILL BE REMOVED ON NEXT ISSUE. PLEASE CONTACT IF YOU WANT IT TO CONTINUE ADD IN NEXT ISSUE 6DAYS BEFORE NEXT ISSUE.**

### MGB 1966 MK1

\$12,500 neg.

Very nice car. 5 speed gearbox, weber, electronic ignition, new fabric roof, good taunea, new chrome, spoked wire wheels, oil cooler, new carpets, good tyres. RWC will be supplied. Restored 7 years ago Phone - 0421112161 eMail - pmgilbert@netspace.net.au



### Your Car

\$\$\$\$\$\$\$\$ neg.

Short information about vehicle or parts. Short information about vehicle or parts.

Short information about vehicle or parts.

Phone - 0000000000

eMail -

xxxxxxx@aussy.com.au



## 2011 CALENDAR

### FEBRUARY

- Sunday, 6 Drive Day \* Meet at Palleranda Loop 10.00am
- Sunday, 13 Drive Day \* Meet at Cluden Race course 10.00am
- Saturday, 19 Evening Social Drive
- Sunday, 20 Drive Day \* Meet at Bohle Pub 10.00am
- Sunday, 27 Drive Day \* Meet at Ross Dam 10.00am

### MARCH

- Tuesday, 1 Pubs of Townsville Upper Ross Hotel Pubs of Townsville Upper Ross Hotel
- Sunday, 6 Drive Day \* Meet at Palleranda Loop 10.00am
- Sunday, 13 Drive Day \* Meet at Cluden Race course 10.00am
- Saturday, 19 Evening Social Drive
- Sunday, 20 Drive Day \* Meet at Bohle Pub 10.00am
- Saturday, 26 Come and Try Race Day
- Sunday, 27 TCAC Hill Climb round 1 TCAC Hill Climb round 1  
Drive Day \* Meet at Ross Dam 10.00am

### APRIL

- Sunday, 3 Round 1 Mareeba Sprint Round 1 Mareeba Sprint  
Drive Day \* Meet at Palleranda Loop 10.00am
- Sunday, 10 Observation Run
- Saturday, 16 Zinc 100.7 Sprint Series Round 1
- Sunday, 17 Drive Day \* Meet at Cluden Race course 10.00am
- Sunday, 24 Drive Day \* Meet at Bohle Pub 10.00am
- Tuesday, 26 The Great MGTC and other Square Rigger's Strand Drive

## 2011 CALENDAR

### MAY

- Sunday, 1 Drive Day \* Meet at Ross Dam 10.00am
- Saturday, 7 20th Anniversary Dinner To be confirmed
- Sunday, 8 Drive Day \* Meet at Palleranda Loop 10.00am
- Saturday, 14 Zinc 100.7 Sprint series Round 2 and Social Run to Sprint event
- Sunday, 15 Drive Day \* Meet at Cluden Race course 10.00am
- Sunday, 22 Drive Day \* Meet at Bohle Pub 10.00am
- Saturday, 28 Evening Social Drive
- Sunday, 29 TCAC Hill Climb round 2

### JUNE

- Sunday, 5 Drive Day \* Meet at Palleranda Loop 10.00am
- Saturday, 11 Towers Swap Meet
- Sunday, 12 Social Drive to Swap Meet
- Saturday, 18 Drive Day \* Meet at Cluden Race course 10.00am
- Sunday, 19 Round 2 Mareeba Sprint  
All British Meet
- Saturday, 25 Zinc 100.7 Sprint Series Round 3
- Sunday, 26 Drive Day \* Meet at Bohle Pub 10.00am

### JULY

- Saturday, 2 Camp Quality Strand Cruise
- Sunday, 3 Camp Quality Strand Car Show
- Thursday, 7 Centenary Hotel Pubs of Townsville Dinner
- Friday, 8 **TOWNSVILLE 400 V8 SUPERCARS**
- Saturday, 9 **TOWNSVILLE 400 V8 SUPERCARS**
- Sunday, 10 **TOWNSVILLE 400 V8 SUPERCARS**

## 2011 CALENDAR

### JULY cont.

- Saturday, 16 Drive Day \* Meet at Ross Dam 10.00am
- Sunday, 17 Mt Stuart Breakfast
- Saturday, 23 Zinc 100.7 Sprint Series Round 4
- Sunday, 24 TCAC Hill Climb round 3  
Drive Day \* Meet at Palleranda Loop 10.00am
- Saturday, 30 Christmas in July
- Sunday, 31 Drive Day \* Meet at Cluden Race course 10.00am

### AUGUST

- Saturday, 6 Drag Meet
- Sunday, 7 Round 3 Mareeba Sprint  
Drive Day \* Meet at Bohle Pub 10.00am
- Saturday, 13 Poker Run
- Sunday, 14 Drive Day \* Meet at Ross Dam 10.00am
- Saturday, 20 Zinc 100.7 Sprint Series Round 5
- Sunday, 21 Drive Day \* Meet at Palleranda Loop 10.00am
- Sunday, 28 Drive Day \* Meet at Cluden Race course 10.00am
- Monday, 29 Vic Park Hotel Pubs of Townsville

### SEPTEMBER

- Saturday, 3 Ingham Wings and Wheels
- Sunday, 4 Drive Day \* Meet at Bohle Pub 10.00am
- Saturday, 10 Drive Day \* Meet at Ross Dam 10.00am
- Sunday, 11 Strand Breakfast
- Saturday, 17 Marque Strand Car
- Sunday, 18 Drive Day \* Meet at Palleranda Loop 10.00am
- Saturday, 24 Zinc 100.7 Sprint Series Round 6
- Sunday, 25 Drive Day \* Meet at Cluden Race course 10.00am

## 2011 CALENDAR

### OCTOBER

- Sunday, 2 TCAC Hill Climb round 4  
Drive Day \* Meet at Bohle Pub 10.00am
- Sunday, 9 Drive Day \* Meet at Ross Dam 10.00am
- Wed, 5 West End Hotel Pubs Of Townsville
- Saturday, 15 Zinc 100.7 Sprint Series Round 7
- Sunday, 16 Round 4 Mareeba Sprint  
Drive Day \* Meet at Palleranda Loop 10.00am
- Saturday, 22 Social Drive Northern Beaches Bushland Beach Hotel Lunch
- Sunday, 23 Drive Day \* Meet at Cluden Race course 10.00am
- Sunday, 30 Drive Day \* Meet at Bohle Pub 10.00am

### NOVEMBER

- Saturday, 5 Poker Run
- Sunday, 6 Drive Day \* Meet at Ross Dam 10.00am
- Sunday, 13 Drive Day \* Meet at Palleranda Loop 10.00am
- Saturday, 19 Social Drive To Club Christmas Party
- Sunday, 20 Drive Day \* Meet at Cluden Race course 10.00am
- Sunday, 27 Drive Day \* Meet at Bohle Pub 10.00am

### DECEMBER

- Sunday, 4 Drive Day \* Meet at Ross Dam 10.00am
- Sunday, 11 Drive Day \* Meet at Palleranda Loop 10.00am
- Wed, 14 Bohle Hotel Pub of Townsville Dinner
- Saturday, 17 Christmas Lights tour
- Sunday, 18 Drive Day Meet at Cluden Race course 10.00am

## 2012 CALENDAR

### JANUARY 2012

- Sunday, 1     Drive Day \*     Meet at Bohle Pub 10.00am
- Sunday, 8     Drive Day \*     Meet at Ross Dam 10.00am
- Sunday, 15    Drive Day \*     Meet at Palleranda Loop 10.00am
- Sunday, 22    Drive Day \*     Meet at Cluden Race course 10.00am
- Sunday, 29    Breakfast meeting to Set the Calendar for 2012

#### Drive Day\*

Participants will meet at nominated start point at 10.00am. This will enable 1 car to go on there own without having to contact others to go for a drive.

## MARQUE SPORTS CAR REGISTER NORTH QUEENSLAND INC.

We're on the WEB  
[WWW.MARQUENQ.COM.AU](http://WWW.MARQUENQ.COM.AU)

This year the Marque NQ Club  
is in its twentieth year.

The original idea of the club was to have as large an assortment of types of vehicles and members as possible. Over 100 registered members are involved in the club centered around racing and road vehicles of all ages and description.

If you have been thinking about joining a club that is slightly laid back and more interested in you enjoying your vehicle than club meetings, then have a look at us for a chance to enjoy the varied members and vehicles, that have been attracted to this growing club.

## DID YOU KNOW

### MYTH: OLDER VEHICLES REQUIRE LEADED GASOLINE

According to popular belief, using unleaded gasoline in older cars with "soft" exhaust valve seats causes engine damage. This is because lead, which is added to gasoline to boost octane, also coats valve seats made with cast iron or soft steel. It is argued that without the lubrication that lead additives provide, these soft valve seats will wear down, a phenomenon known as "valve seat recession."

**Reality: All Cars Can Operate on Unleaded Gasoline**

Extensive research and actual experience confirm that all cars – including older ones with soft valve seats – can operate on unleaded gasoline under normal driving conditions. Even in the case of engines subjected to high stress, such as in heavy duty farm equipment and motorcycles, unleaded gasoline has not caused significant engine damage. Valve seat recession is unlikely to occur except in extreme conditions – for example when vehicles are run constantly for

days on end, and at high speeds, and carrying heavy loads.

In countries where vehicle fleets are very old (the U.S. and Europe stopped producing cars with soft valve seats in the 1970s), the use of alternative additives that provide valve seat lubrication protects against any small risk of valve seat recession.

This strategy has been used successfully in some countries, including the Slovak Republic. In any case, switching from leaded to unleaded gasoline reduces vehicle maintenance costs overall. This is because lead additives cause far more damage to engines than they prevent, by corroding exhaust valves, exhaust pipes, spark plugs, and mufflers. As a result, vehicles using unleaded gasoline need fewer tune-ups and part replacements. A 1985 U.S. EPA study on the costs and benefits of

leaded gasoline phase-out confirmed that switching to unleaded gasoline provides significant savings in maintenance costs to drivers.

Fears of valve seat recession are illusionary. All cars can operate safely on unleaded fuels, often at lower cost.

This extract is from the United Nations Environment Programme UNEP website [www.unep.org/pcfv/publications/publications.asp](http://www.unep.org/pcfv/publications/publications.asp)

Reported by the Partnership for Clean Fuels and Vehicles (PCFV)

#### THEORETICAL VALVE SEAT RECESSION IN OLDER OBSOLETE ENGINES

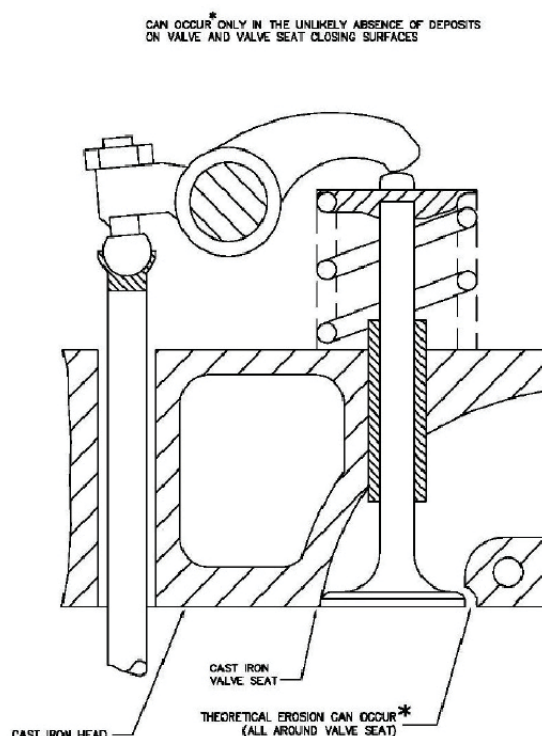

\* EROSION ONLY FOUND AFTER CONSTANT HIGH ENGINE SPEED ACCELERATED LABORATORY TESTS. EROSION VIRTUALLY NOT FOUND WHEN VEHICLES ARE USED FOR EVERYDAY NORMAL OPERATION.